



WEEN KIT BASE

A/R PER CE 160 KG



Anta ribalta Ween 160 kg CE | Ween tilt and turn CE 160 KG |
Oscillo-battant Ween 160 KG | Oscilobatiente Ween 160 KG



Cerniere in alluminio estruso e zama, rinvio d'angolo, terminali e riscontri in zama, piastrine e viti in acciaio inox. Portata massima: 160 Kg



Hinges in extruded aluminum and zamak, corner return, terminals and handles in zamak, plates and screw in stainless steel. Maximum load: 160 Kg



Paumelles en aluminium extrudé et zamak, renvoi d'angle, embout de tringle et gâches en zamak, plaques en acier inox. Portée: 160 Kg



Bisagras de aluminio extruido y zamac, reenvio de ángulo bloqueo y cerradero de zamac, plaquetas inox. Soporta hasta: 160 kg



ART.	3450F.1				3450LF.1			
Imballo Package Conditionnement Embalaje	5 Kit				5 Kit			
Finiture disponibili Available finishes Finitions disponibles Acabados disponibles	1	2	3	4	1	2	3	4

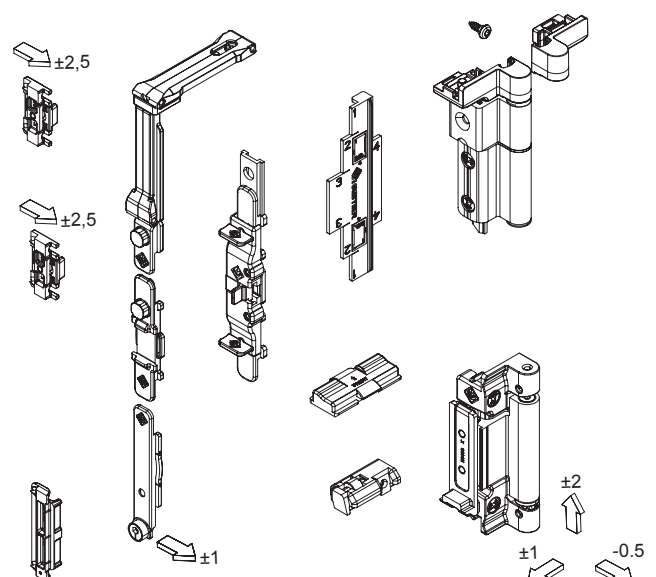
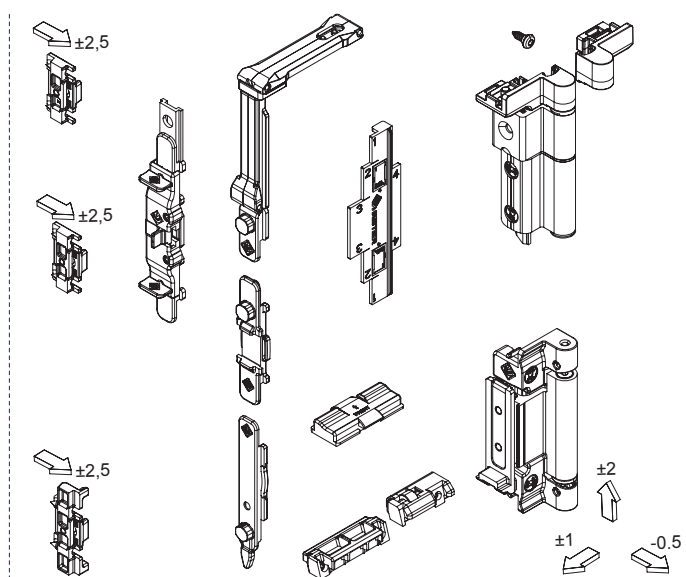

Art. 3450F.1
Kit base standard con **antifalsamanovra superiore**
Standard kit with **upper anti-false manoeuvre (AFM)**

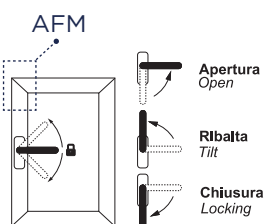

Art. 3450LF.1
Kit base manovra logica con **antifalsamanovra superiore**
Logic version with **upper anti-false manoeuvre (AFM)**

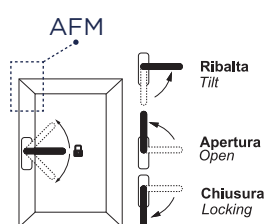

ABBINABILI A MOVIMENTAZIONI: 3627.10 | 3627.12 | 3627F.11 | 3627F.13 | 3630.30 | 3630F.30

ART.	NODO SECTION
3420F.1 3450F.1 3420LF.1 A3450LF.1	A01 - A02 - A04 - A05 - A06



Portate > 100 kg e < 160 kg vite obbligatoria
Compulsory for sah weight > 100kg < 160 kg

PESO MASSIMO DELL'ANTA (alluminio + vetro = 160 Kg) MAXIMUM WEIGHT OF THE SASH (alluminium + glass =160 Kg)															
Spessore max. del vetro indicato (es. 30 mm) Maximum thickness of the glass (es. 30 mm)							N.D. = Dimensione Non Disponibile N.D. = Dimension Not Available								
Nota: Lo spessore massimo del vetro impiegabile si riferisce al materiale senza la camera d'aria Note: The maximum thickness of the glass is considered without the air-space															
2700	50	50	47	40	34	30	26	24	22	20	18	17	16	15	14
2600	50	50	49	41	35	31	27	25	22	21	19	18	16	15	14
2500	50	50	50	43	37	32	28	26	23	21	20	18	17	16	15
2400	50	50	50	44	38	33	30	27	24	22	21	19	18	17	16
2300	50	50	50	46	40	35	31	28	25	23	21	20	19	17	16
2200	50	50	50	48	42	36	32	29	26	24	22	21	19	18	17
2100	50	50	50	50	44	38	34	30	28	25	23	22	20	19	16
2000	50	50	50	50	46	40	36	32	29	27	25	23	21	20	17
1900	50	50	50	50	48	42	37	34	31	28	26	24	22	19	18
1800	50	50	50	50	50	44	40	36	32	30	27	25	21	20	19
1700	50	50	50	50	50	47	42	38	34	31	29	24	23	21	20
1600	50	50	50	50	50	50	44	40	36	33	28	26	24	23	18
1500	50	50	50	50	50	50	47	43	39	36	30	27	26	20	15
1400	50	50	50	50	50	50	50	46	42	34	32	29	23	17	16
1300	50	50	50	50	50	50	50	49	40	37	34	26	20	18	12
1200	50	50	50	50	50	50	50	48	44	40	31	23	21	13	6
1100	50	50	50	50	50	50	50	50	48	36	27	25	16	7	x
1000	50	50	50	50	50	50	50	50	44	32	30	18	9	x	x
900	50	50	50	50	50	50	50	43	39	24	11	x	x	x	x
800	50	50	50	50	50	50	50	48	29	13	x	x	x	x	x
700	50	50	50	50	50	50	50	18	x	x	x	x	x	x	x
600	50	50	50	50	50	50	24	x	x	x	x	x	x	x	x
500	50	50	50	50	x	x	x	x	x	x	x	x	x	x	x
	370	400	500	600	700	800	900	1000	1100	1200	1300	1400	1500	1600	1700

CONFIGURAZIONI | CONFIGURATIONS

KIT BASE= 3420F.1
3450F.1

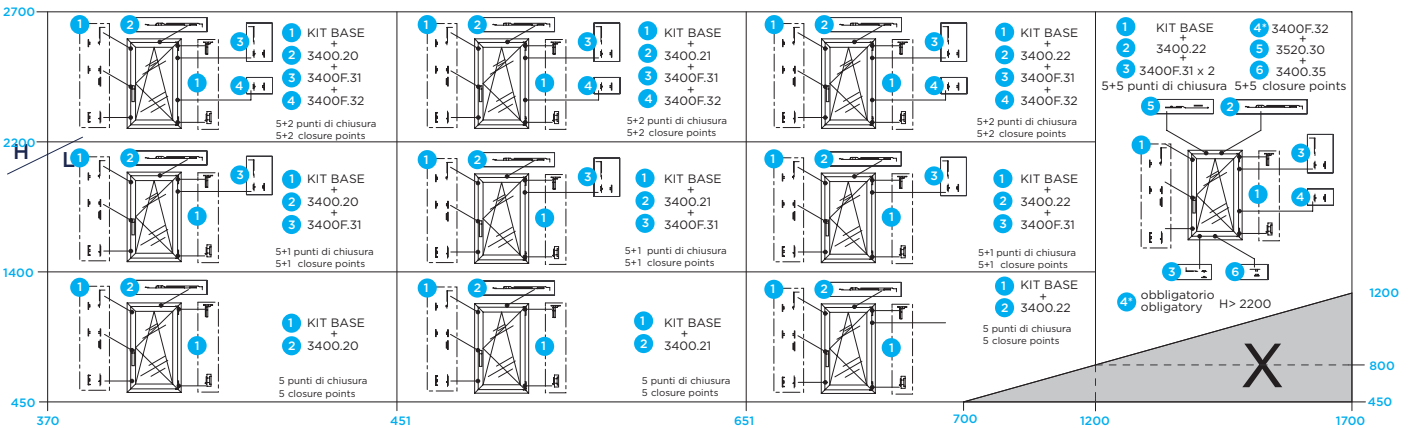

KIT BASE= 3420LF.1
3450LF.1

