

APRO

Windows Automation
SCHEDA TECNICA DI MONTAGGIO

**Gamma Automazioni
24V DC**

Attuatore a catena 250N 24V
Chain actuator 250N 24V

Art. A1124.X

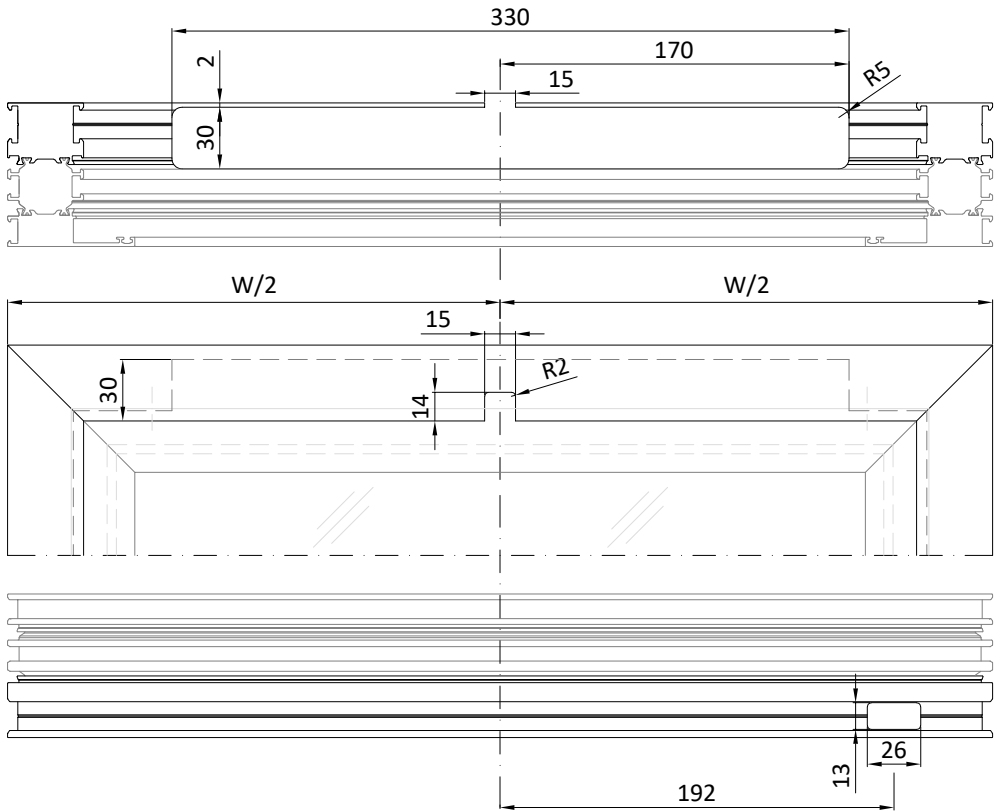
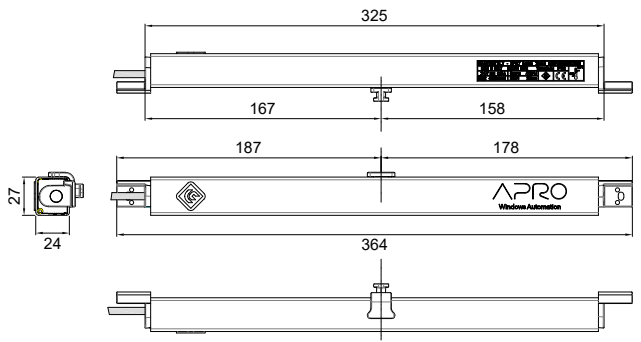
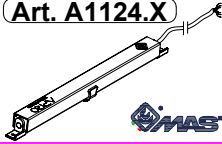

APRO

Windows Automation
SCHEMA TECNICA DI MONTAGGIO

Gamma Automazioni
24V DC

Elettro-serratura 600N 24V
Electro-lock 600N 24V

Art. A1125.X

